

Art of **P**recision & **P**erformance

Vcenter-P76 (APC) P106 / P136

Vertical machining center

- **Rapid feeds 48/48/32 m/min (Vc-P76/P106)**
- **12000rpm spindle output 18.5 KW(s3)**
- **BBT-40 / 30 tools**
- **Roller guideways**
- **Bottom guarding flush (Vc-P106/P136)**
- **Screw chip removers**



Victor Taichung – an established ISO 9001, 14001 & 45001 company



Vcenter-P series High Performance VMC

- X-travel 760/1060/1360 mm for Vc-P76/P106/P136
- High rapid feed 48 m/min (32 m/min for P136)
- High speed 12000rpm spindle
- Electrical counterbalance

ATC

- 2.2 (6.0) sec. (P76)
- 2.3 (6.3) sec. (P106)
- 2.3 (7.7) sec. (P136)
- T-T (chip-chip)

30

Tools

Magazine

Feeds & Travels

48/48/32 (P76/P106)

32/32/32 (P136)

X/Y/Z (m/min)

760 / 500 / 510 (P76)

1060 / 600 / 560 (P106)

1360 / 700 / 700 (P136)

X/Y/Z (mm)

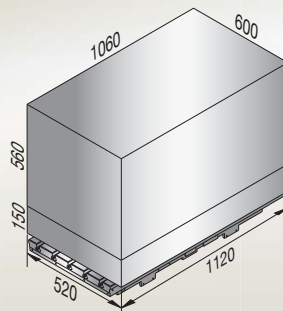

e.g. Vc-P106

Table & Guideways

500 kg (P76)

600 kg (P106)

1000 kg (P136)



840 x 500 mm (P76)

1120 x 520 mm (P106)

1400 x 700 mm (P136)

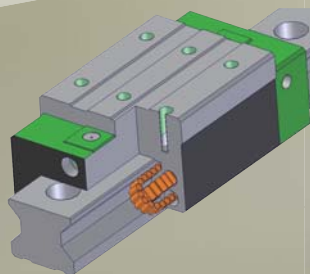

Roller guides X/Y/Z (mm)

30 / 35 / 45 (P76)

35 / 45 / 45 (P106)

45 / 35 (4 off) / 45 (P136)

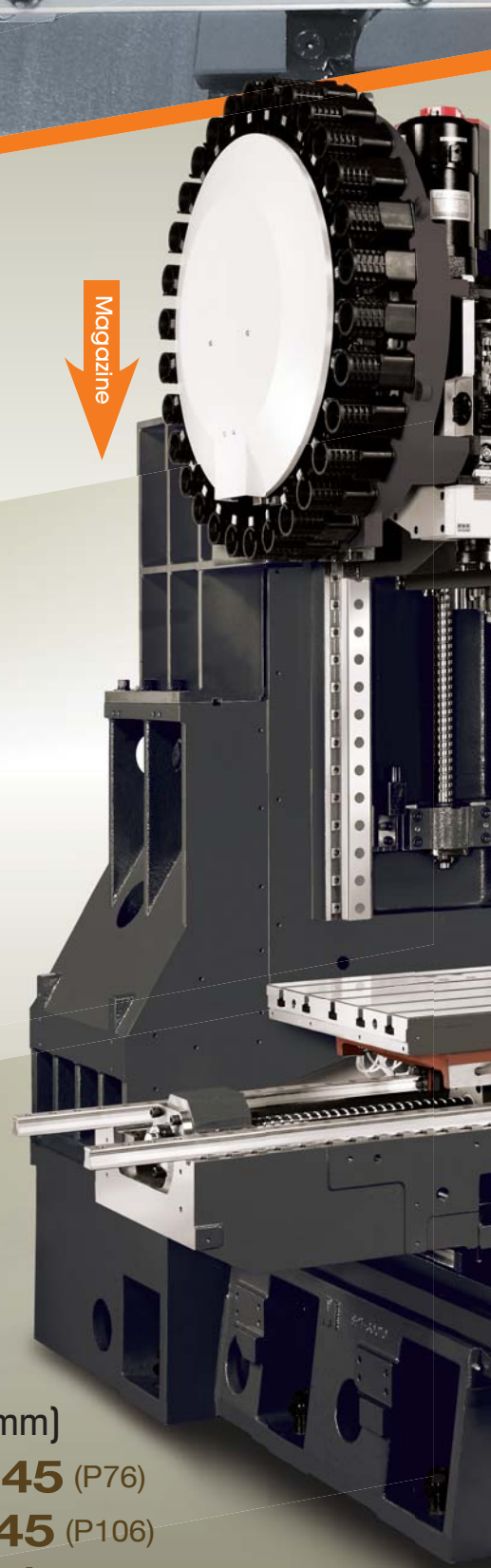



Spindle BBT-40

18.5 kW* (S3-25%)

12000rpm

(* opt. 15 kW with CTS)



Fanuc α i12/12000 (std. without CTS)

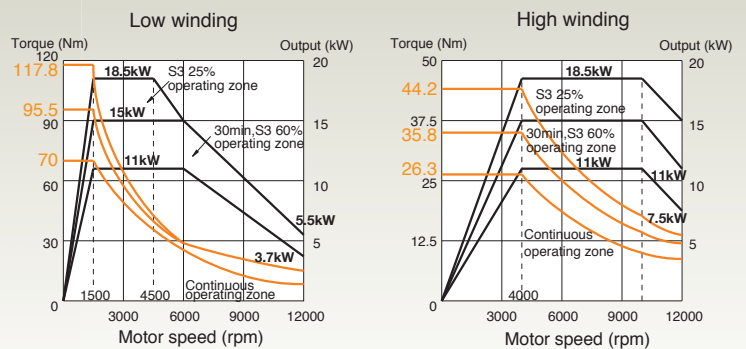

Fanuc α T8/12000 (opt. with CTS)

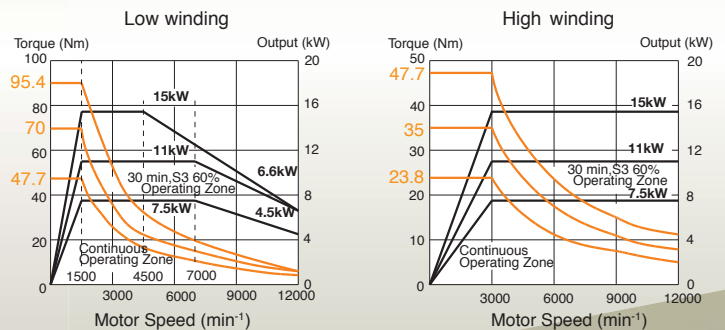

Structure



Certificated Casting

GA350

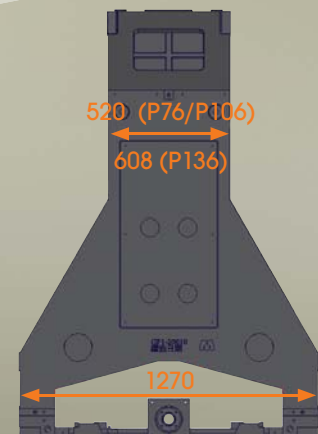

Wide column

1166 mm (P76)
1270 mm (P106/P136)

Vcenter-P series

Standard Accessories

New Fanuc Oi-MF Plus (type-1) control includes:

- 10.4" screen
- 2GB CF card (incl.)
- AICC-2 (200 blocks)
- Manual Guide i (MGI)
- QWERTY keyboard
- VSS Macros (Victor's GUI)

Victor Taichung's GUI "VSS macros"

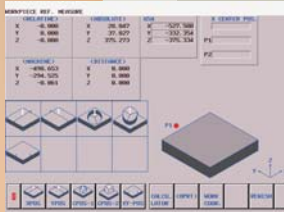

Smart workpiece measurement

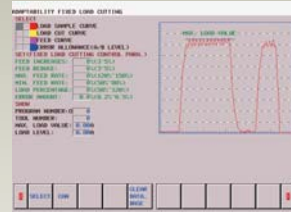

Adaptive cutting at constant loading

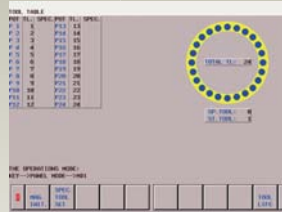

Tool management



Renishaw® GUI

Spindle oil cooler



Arm type ATC + Auto door for magazine + Coolant ring + LED lights



Heat exchanger + Enclosed rear guarding

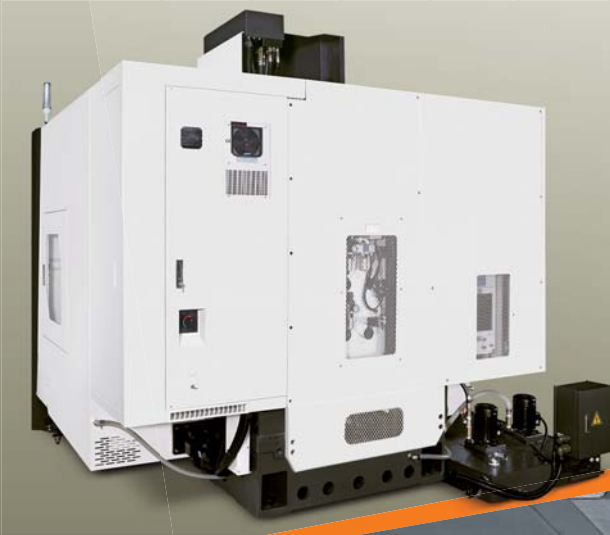

Bottom guarding flush (Vc-P106/P136) + screw chip remover (4 screws for P136)





Optional Accessories

CTS (Coolants Thru. Spindle)



Auto tool length measurement



Auto part measuring



4th axis interface for rotary table



15" screen (opt.)

Linear scales



Chip conveyor



Vcenter-P76APC

Auto Pallet Changer

- APC mechanism seated on ground for high rigidity
- Pallet dimension 720mm x 400mm
- Pallet exchange time: 15 seconds (incl. air sealing detection time)
- Control panel at right side for easy operation
- Linear scales and 4th axis can be installed

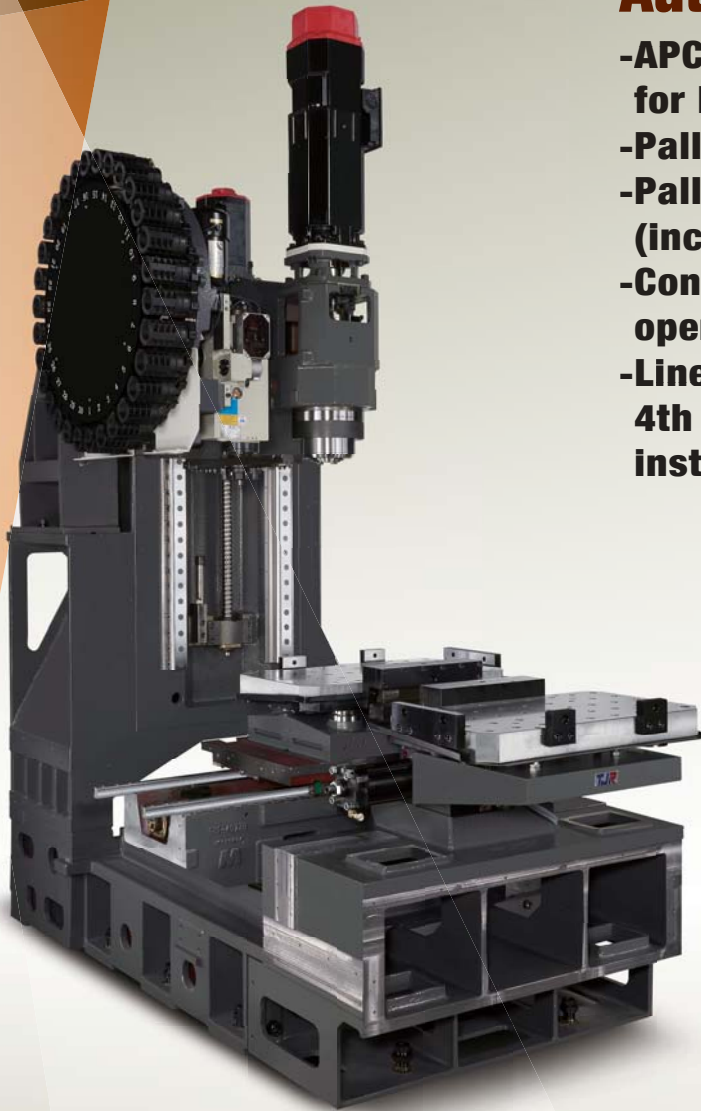

Pallet dimension

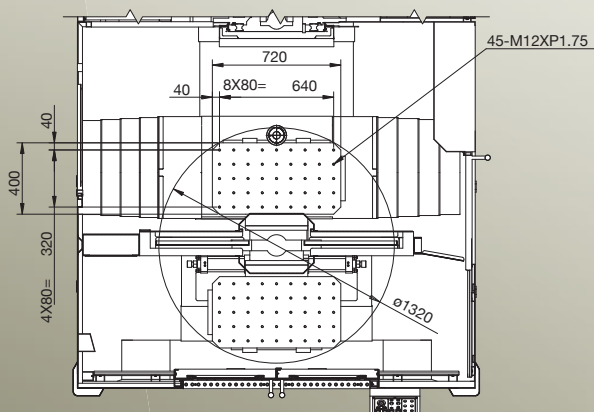

Machining range

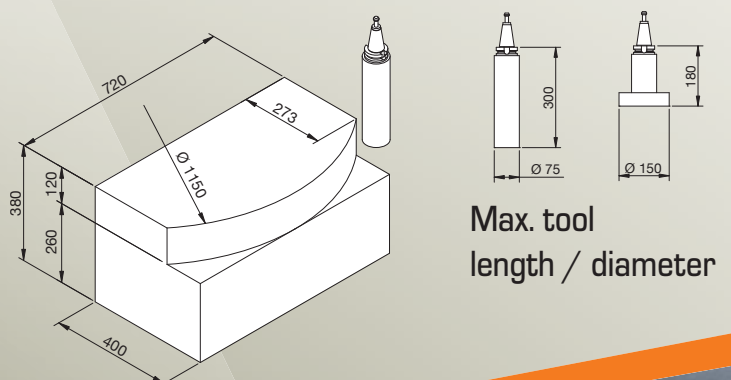

VICTOR Taichung's NC PACKAGE



Heidenhain TNC-620/640 controls

- Powerful dialog programming
- Fully alphanumeric keyboards
- Preview contouring 5000 blocks
- 15" screen
- HR-510 hand wheel

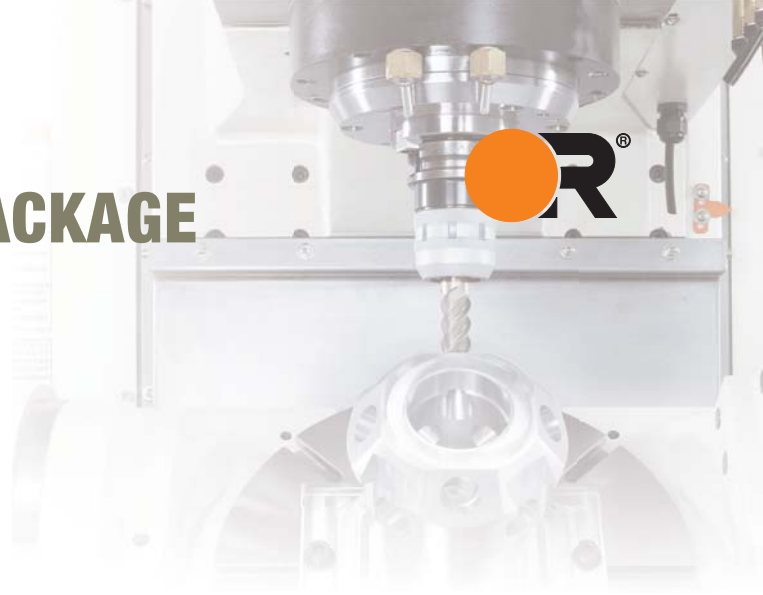

Spindle Output (Heidenhain)

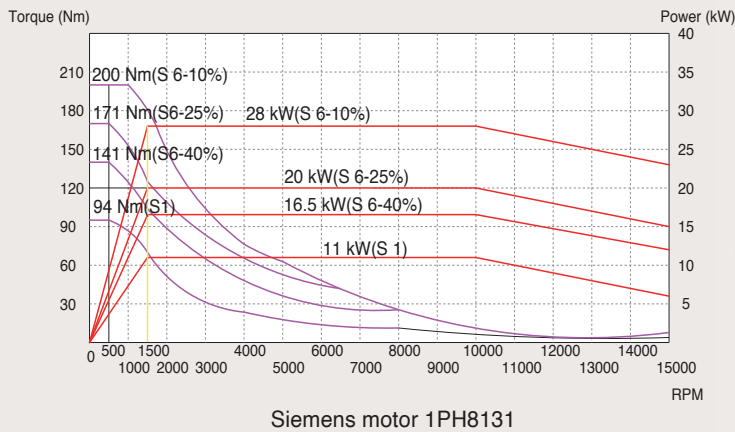

Control features for fast contour milling

Feature \ Controller	FANUC			HEIDENHAIN	
	0i-MF Plus (type 1)	0i-MF Plus (type 0)	31i-B	TNC-620	TNC-640
Block addressing time	1 ms	0.4 ms	0.4 ms	1.5 ms	0.5 ms
Preview contouring (look ahead blocks)	200	200 (Opt. 400)	600 (Opt. 1000 by HSP)	5000	5000
Graphic display	10.4"	15" (Opt. 10.4")	10.4" (Opt. 15")	15"	15" (Opt. 19")
Data storage	5120m (2MB)	5120m (2MB)	2560m (1MB) Opt. 10240m (8MB)	Min. 2GB	Std. 21GB (by SSRD) Opt. 144GB (by HRD)
Memory extension	Std. (CF card, 2GB)	Std. (CF card, 2GB)	Std. (by CF card)	Opt. (by USB)	N.A.
DATA SERVER	Opt. (by CF Card)	Opt. (by CF Card)	Std.	Std.	Std.
Ethernet link	Std.	Std.	Std.	Std.	Std.
Touch panel	N.A.	Incl.	Opt.	Opt.	Opt. (Std. for 19")
Conversational function	Manual guide I (MGI) + VSS macros	Panel iH (iHMI) + MGI + VSS macros	MGI + VSS macros	Std.	Std. + SmartNC
Data transfer interface	PCMCIA + USB	PCMCIA + USB	PCMCIA + USB	USB	USB

Machine Specification

Item	Unit	Vcenter-P76 Vcenter-P76APC	Vcenter-P106	Vcenter-P136	
Travel	X axis travel	mm	760	1060	1360
	Y axis travel	mm	500	600	700
	Z axis travel	mm	460	560 (opt. 760)	700
Distance	Spindle center to column	mm	510 (opt. 690)	560 (opt. 760)	700
	Spindle nose to table surface	mm	540	627	792
Table	Table work area	mm	120 ~ 630 (opt. 810)	150 ~ 710 (opt. 910)	100 ~ 800
	Dimension of T-slot	mm	840 x 500 720 x 400	1120 x 520	1400 x 700
	Max. table load	kg	4 x 18 x 100 45-M12 (80 x 80)	5 x 18 x 100	7 x 18 x 100
Spindle	Spindle taper		500 200	600	1000
	Spindle motor - cont/ 60%/25% (Fanuc)	kW	BBT-40	BBT-40	BBT-40
	Spindle motor - cont/ 40%/25%/10% (Heidenhain)	kW	11 / 15 / 18.5 (w/t CTS)	11 / 15 / 18.5 (w/t CTS)	11 / 15 / 18.5 (w/t CTS)
	Spindle speed	rpm	7.5 / 11 / 15 (for CTS)	7.5 / 11 / 15 (for CTS)	7.5 / 11 / 15 (for CTS)
	Rapid feed rate - X/Y/Z (Fanuc)	m/min	11 / 16.5 / 20 / 28	11 / 16.5 / 20 / 28	11 / 16.5 / 20 / 28
Feed rate	Rapid feed rate - X/Y/Z (Heidenhain)	m/min	12000 (opt. 15000)	12000 (opt. 15000)	12000 (opt. 15000)
	Axis acceleration - X/Y/Z	m/sec ²	48 / 48 / 32	48 / 48 / 32	32 / 32 / 32
	Axis feed motor - X/Y/Z (Fanuc)	kW	48 / 48 / 32	48 / 48 / 32	36 / 36 / 36
	Axis feed motor - X/Y/Z (Heidenhain)	kW	0.7G / 0.7G / 0.5G	0.7G / 0.7G / 0.5G	0.4G / 0.4G / 0.5G
	Cutting feedrate by table	m/min	3 / 3 / 3	3 / 3 / 3	3 / 3 / 3
	X/Y/Z ballscrew (dia. x pitch)	mm	4.5 / 4.5 / 5.4	4.5 / 4.5 / 5.4	5.1 / 5.4 / 8.6
	Linear guide width (X/Y/Z)	mm	20	20	20
	Max. tool length	mm	40 x P16 (X) 40 x P16 (Y/Z)	45 x P16 (X) 40 x P16 (Y/Z)	45 x P16 (X) 45 x P16 (Y/Z)
	Max. tool weight	kg	30 / 35 / 45	35 / 45 / 45	45 / 35 (4 off) / 45
	Tools	Magazine capacity		300	300
Max. tool diameter (without adjacent tools)		mm	7	7	7
Tool exchange time		sec.	30 (opt. 40)	30 (opt. 40)	30 (opt. 40)
Pull stud angle		deg.	75 (150)	75 (150)	75 (150)
Tool selection method			2.2 (T-T), 6.0 (C-C)	2.3 (T-T), 6.3 (C-C)	2.3 (T-T), 7.7 (C-C)
Positioning accuracy (bi-directional)		mm	15 (JIS 40P)	15 (JIS 40P)	15 (JIS 40P)
Repeatability		mm	Random	Random	Random
Accuracy (ISO 230-2)	Power requirement	KVA	0.010	0.010	0.010
	Min/Max. air pressure	kg/cm ²	0.007 (±0.0035)	0.007 (±0.0035)	0.007 (±0.0035)
	Coolant tank capacity	L.	23 (excl. CTS)	23 (excl. CTS)	23 (excl. CTS)
	Std. NC controller (Fanuc)		5.5 ~ 6.5	5.5 ~ 6.5	5.5 ~ 6.5
	Opt. NC controller (Heidenhain)		260	270	350
Machine	Floor space requirement	mm	2731 2920	3363 x 2812	4293 x 2963
	Max. machine height	mm	2750 x 2719 2750 x 3227	2841	3074
	Machine weight	kg	2731 2920	6450	8880
			5500 6500		

Standard Accessories:

- Fully enclosed splash guard
- Fanuc Oi-MF Plus (10.4") control
- Spindle oil cooler
- Screw-type chip remover (left disposal)
- Bottom guarding flushing coolants (Vc-P106/P136)
- Rigid tapping
- Remote MPG
- Hand tools and toolbox
- T nuts for table slot
- 3-step warning light
- Auto power off
- Leveling pads

Optional Accessories:

- Air conditioner for electric cabinet
- Chip conveyor
- Coolant through spindle (CTS)
- 40 tool magazine
- Auto tool length measurement
- Auto part measuring
- Stop block for special tools
- 4th/5th axis interface
- Auto door
- Oil skimmer
- Air gun
- Coolant gun
- 15000 rpm spindle (DCS)
- Linear scales
- Rotary tables
- Higher column with extended Z-axis travel 760mm (for Vc-P106)

Tool Shank

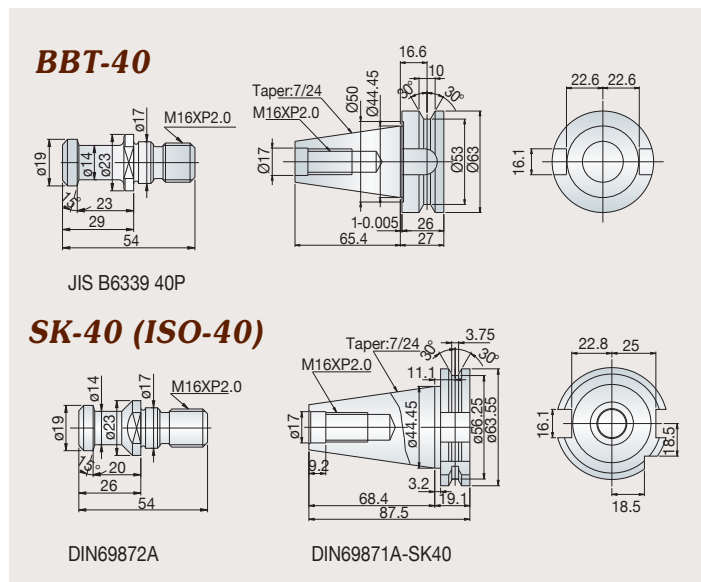

Machine Color Option



VICTOR's FANUC Oi-MF Plus(Type 1)/31i-B Control Specification

Standard

ITEM	SPECIFICATION	DESCRIPTION
Controlled Axes		
1.	Controlled Axes	3 Axes (X, Y, Z)
2.	Simultaneous Controlled Axes	4 Axes
3.	Least Input Increment	0.001 mm / 0.0001 inch / 0.001 deg.
4.	Least Input Increment 1/10	0.0001 mm / 0.00001 inch / 0.0001 deg.
5.	Max. command value	± 99999.999 mm (± 9999.9999 in)
6.	Inch / Metric Conversion	Std. (G20/G21)
7.	Interlock	All Axes / Each Axis / Cutting Block Start
Operation		
1.	Automatic Operation	Std.
2.	MDI Operation	MDI B
3.	DNC Operation	Reader / Puncher Interface is Required
4.	DNC Operation with Memory Card	PCMCIA Card Attachment is Required
5.	Manual Handle Feed	1 Unit / Each Path
6.	Manual Handle Feed Rate	X1, X10, X100
Interpolation		
1.	Positioning	G00
2.	Exact Stop Mode	G61
3.	Exact Stop	G09
4.	Linear Interpolation	G01
5.	Circular Interpolation	G02, G03 (multi-quadrant is possible).
6.	Dwell	G04
7.	Helical Interpolation	Std.
8.	Skip Function	G31
Feed		
1.	Rapid Traverse Rate	Std.
2.	Rapid Traverse Override	F0, 25%, 50%, 100%
3.	Feed Per Minute	G94 (mm/min)
4.	Tangential Speed Constant Control	Std.
5.	Cutting Feed rate Clamp	Std.
6.	Automatic Corner Deceleration	Std. (G64)
7.	Feed rate Override	0-200%
8.	Jog Override	0-100%
9.	Automatic Corner Override	G62.
10.	Feed Stop	Std.
11.	AI contour control (AICC, G05.1) (in total)	200 blocks (AICC-2)
12.	AICC-2 + High speed processing (G05.1) (in total)	600 blocks (31)
Program Input		
1.	EIA / ISO Automatic Recognition	Std.
2.	Label Skip	Std.
3.	Parity Check	Std.
4.	Control In / Out	Std.
5.	Optional Block Skip	1
6.	Max. Programmable Dimension	± 8-Digit
7.	Program Number	O4-Digit
8.	Sequence Number	N5-Digit
9.	Absolute / Incremental Programming	G90/G91
10.	(Pocket Calculator Type) Decimal Point Programming	Std.
11.	Input Unit 10 Time Multiply	Std.
12.	Plane Selection	G17, G18, G19
13.	Rotary Axis Designation	Std.
14.	Rotary Axis Roll-Over Function	Std.
15.	Polar coordinate Command	G16.
16.	Coordinate System Setting	Std.
17.	Automatic Coordinate System Setting	Std.
18.	Workpiece Coordinate System	G52, G53, G54-G59
19.	Addition of Workpiece Coordinate System Pair	48 Pairs
20.	Manual Absolute On And Off	Std.
21.	Optional Chamfering/Corner R	Std.
22.	Programmable Data Input	G10
23.	Sub Program Call	4 (0) or 10 (31) folds nested
24.	Custom macro B	Std.
25.	Addition of Custom Macro Common Variables	#100-#199, #500-#999
26.	Canned Cycles For Milling	G73/G74/G76, G80-G89, G98/G99
27.	Small hole peck drilling cycle	G83
28.	Circular Interpolation by R Programming	Std.
29.	Program Format	FANUC std. format
30.	Program Stop / Program End	M00/M01/M02/M30
31.	Reset	Std.
32.	Scaling	G51
33.	Coordinate System Rotation	G68
34.	Programmable mirror image	G50.1
35.	Manual Guide I (MGI) conversational programming	Std.
Auxiliary Spindle Speed Function		
1.	Auxiliary Function Lock	Std.
2.	High Speed M / S / T Interface	Std.
3.	Spindle Speed Function	Std.

4.	Spindle Override	50-200%
5.	1st Spindle Orientation	Std.
6.	M Code / S Code / T code Function	M3 / S5 / T2 digit
7.	Rigid tapping	Std.
Tool Function & Tool Compensation		
1.	Tool Function	T8 digit
2.	Tool Offset Pairs	± 6-digit, 400 (0), 999 (31)
3.	Tool Offset Memory C	STD (D/H codes are separated)
4.	Tool Length Compensation	G43-G44, G45-G48, G49
5.	Cutting Compensation C	Std.
Accuracy Compensation		
1.	Backlash Compensation	Rapid Traverse / Cutting Feed
2.	Stored Pitch Error Compensation	Std.
Edit Operation		
1.	Part Program Storage Length (in total)	5120m (2MB)
2.	Number of Registered programs (in total)	1000
3.	Part Program Editing / Protect	Std.
4.	Background Editing	Std.
5.	Memory Card Editing	Std. (0)
Setting and Display		
1.	Clock Function	Std.
2.	Current Position Display	Std.
3.	Program Display	Program name 31 characters
4.	Parameter Setting and Display	Std.
5.	Self Diagnosis Function	Std.
6.	Alarm Display / Operation History Display	Std.
7.	Alarm History Display	50
8.	Help Function	Std.
9.	Run Hour and Parts Count Display	Std.
10.	Actual Cutting Feedrate Display	Std.
11.	Display of Spindle Speed and T Code At All Screens	Std.
12.	Graphic Function	Std.
13.	Dynamic graphic display	Std. (in MGI)
14.	Data Protection Key	Std.
15.	Erase CRT Screen Display	Std.
16.	Machining Condition Selecting Screen	Std.
17.	Color LCD / MDI	10.4"
Data Input / Output		
1.	Reader / Puncher Interface	RS-232 interface
2.	Memory Card Interface	Std.
3.	Embedded Ethernet (10Mbps)	Std.
4.	USB Device	Std.

OPTIONS

ITEM	SPECIFICATION	DESCRIPTION	
With hardware included		Oi-MF Plus	31i-B
1.	Conversational programming (Manual Guide I) *1	Std.	Std.
2.	Data server (with PCB and CF card 1GB)	<input type="checkbox"/>	Std.
3.	Fast Ethernet (100Mbps, available in Data server)	<input type="checkbox"/>	Std.
4.	15" Screen	<input type="checkbox"/>	<input type="checkbox"/>
5.	Part Program Storage Length 5120m (2MB in total)	<input type="checkbox"/>	<input type="checkbox"/>
6.	Part Program Storage Length 8MB in total	Std.	<input type="checkbox"/>
7.	Look ahead block expansion (400 blocks in total)	<input type="checkbox"/>	N.A.
8.	Quick program restart	<input type="checkbox"/>	<input type="checkbox"/>
9.	Optional block skip 2-9	<input type="checkbox"/>	<input type="checkbox"/>
10.	Profinet	<input type="checkbox"/>	<input type="checkbox"/>
11.	5-axis simultaneous control	N.A.	<input type="checkbox"/> (31-B5)
Without hardware included			
12.	Look ahead block expansion (1000 blocks in total)	N.A.	<input type="checkbox"/>
13.	Tool load monitoring (with Victor own PLC)	<input type="checkbox"/>	<input type="checkbox"/>
14.	Bi-directional Pitch Error Compensation	<input type="checkbox"/>	<input type="checkbox"/>
15.	Cylindrical interpolation (G7.1) (used on 4th axis)	Std.	<input type="checkbox"/>
16.	Interruption type custom macro	N.A.	<input type="checkbox"/>
17.	Addition of work-piece coordinate systems 300 sets	N.A.	<input type="checkbox"/>
18.	Exponential interpolation (G2.3)	N.A.	<input type="checkbox"/>
19.	Smooth interpolation	N.A.	<input type="checkbox"/>
20.	Spiral/conical interpolation	N.A.	<input type="checkbox"/>
21.	Polar coordinate interpolation	N.A.	<input type="checkbox"/>
22.	Floating reference position return	N.A.	<input type="checkbox"/>
23.	Hypothetical axis interpolation (G07)	N.A.	<input type="checkbox"/>
24.	NURBS interpolation	N.A.	<input type="checkbox"/>
25.	Jerk Control	N.A.	<input type="checkbox"/>

Machine Layout

Vcenter-P76

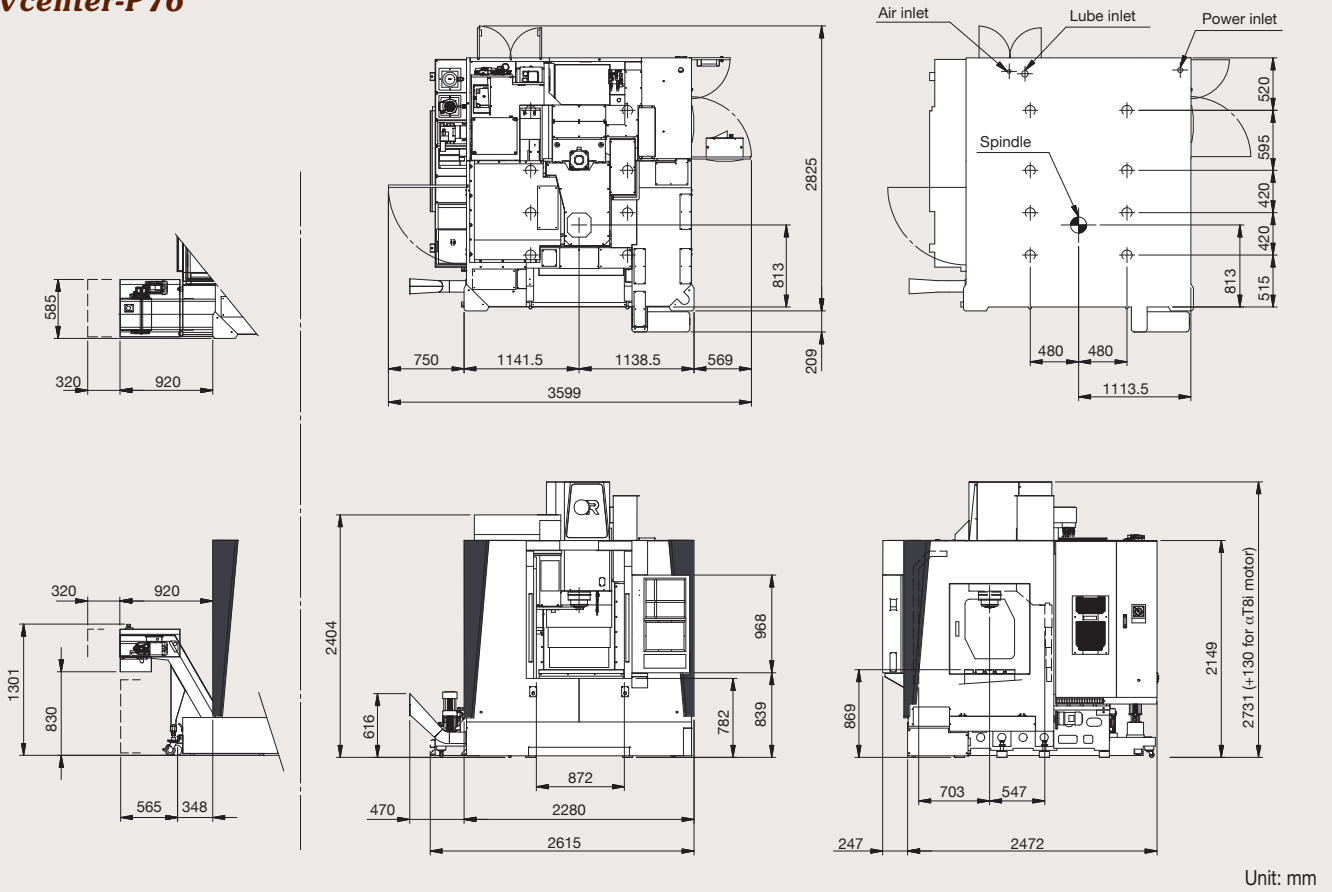

Vcenter-P76APC

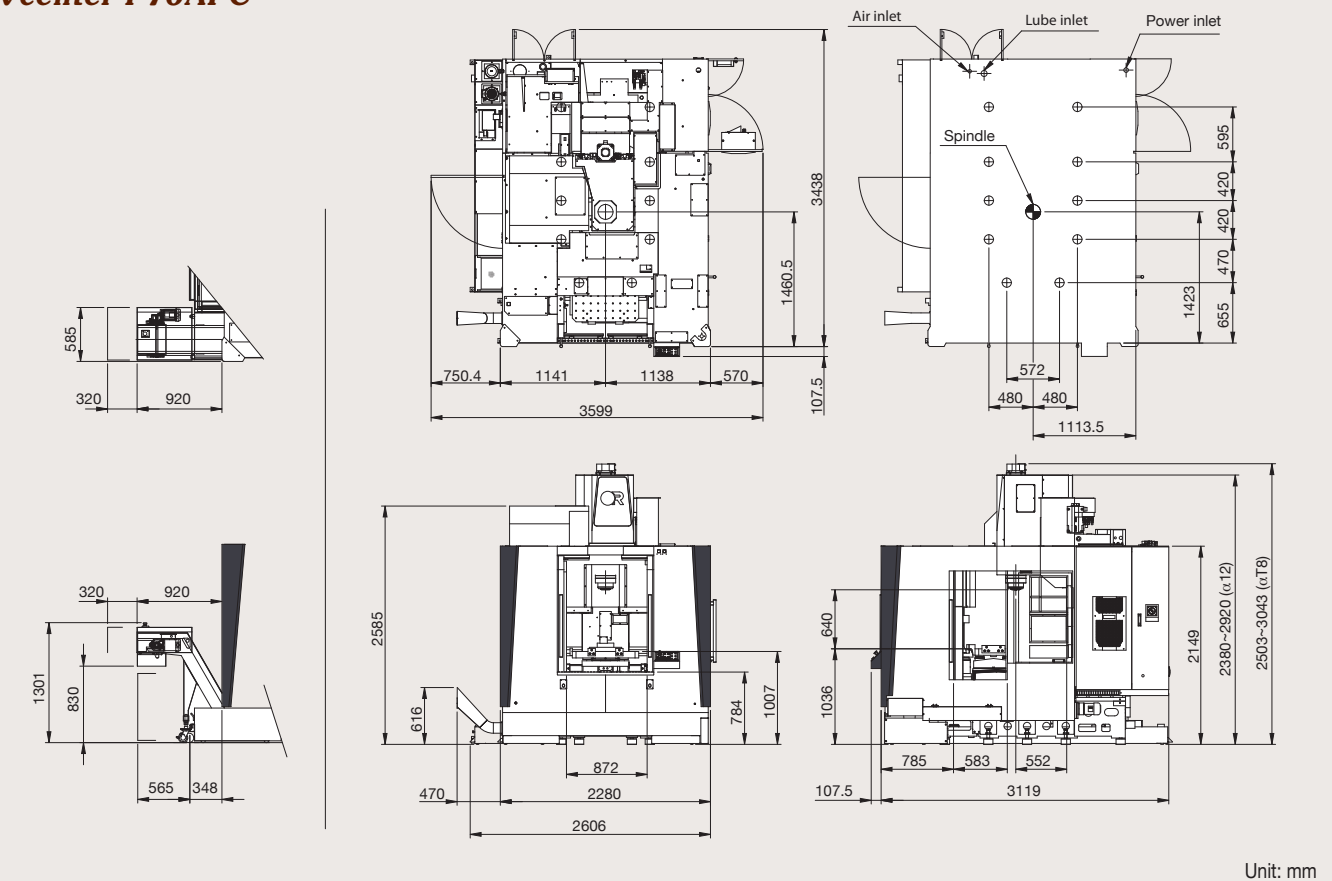

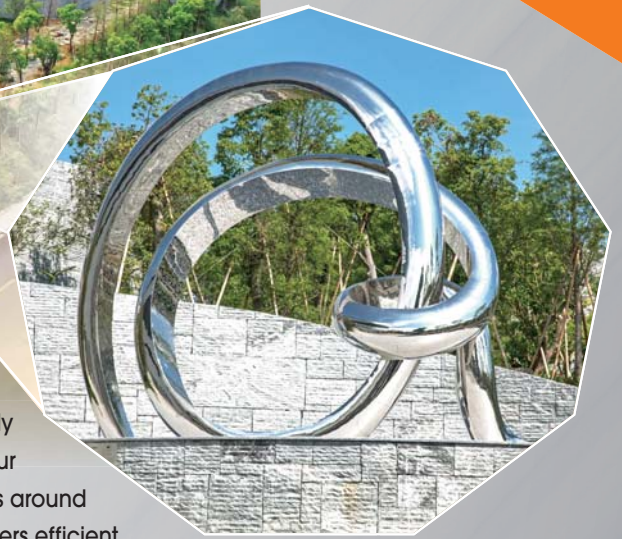

ONWARD RISE

To ensure the return on investment, Victor Taichung has invested considerably in setting up a distribution network in terms of global vision local touch for our sales and service supports worldwide. Besides the qualified exclusive agents around the world, Victor Taichung has 7 overseas subsidiaries to provide our customers efficient after-sales service and technical supports.



Vcenter-P136



 **VICTOR TAICHUNG** profile:
Sales turnover: USD 156 mil's (in 2020)*
No. of employees: 796
*Exchange rate: 1 USD=28.5 TWD.



THE VICTOR-TAICHUNG COMPANIES

TAIWAN

<http://www.victortaichung.com>
E-mail :info@mail.or.com.tw

- Victor Taichung Machinery Works Co., Ltd.
No. 1, Jingke Central 2nd Rd.,
Nantun Dist., Taichung 40852,
TAIWAN, R.O.C.
TEL : 886-4-23592101
FAX : 886-4-23593389

FRANCE

- Victor France
TEL : 33-1-64772000
FAX : 33-1-64772063

GERMANY

- Victor GmbH
TEL : 49-2261-478434
FAX : 49-2261-478327

SOUTH AFRICA

- Victor Fortune (PTY) Ltd.
TEL : 27-11-3923800
FAX : 27-11-3923899

MALAYSIA

- Victor Machinery (M) SDN. BHD.
TEL : 60-3-56337180
FAX : 60-3-56337191

THAILAND

- Victor (Thailand) Co. Ltd.
TEL : 66-2-9263735
FAX : 66-2-9032373

INDONESIA

- PT. Victor Machinery Indonesia
TEL : +62-21-88958504
FAX : +62-21-88958513

USA

- Fortune International Inc.
TEL : 1-732-2140700
FAX : 1-732-2140701

CHINA

- Victor Taichung
Machinery (Shanghai)
TEL : 86-21-59768018
FAX : 86-21-59768009



HTL



VTL



VMC



HMC



XMT



PIM